

# VVM Digital DC Voltage Current Sensor Module 100V 100A with Watt hour, Ampere hour, Serial UART Communication, Over-Current Detection, MODBUS Compatible

Product ID: VVM302  
Version: v1.3

## Features:

- Hall Effect based non-invasive current measurement, no shunt resistor or wire break required, based on WCS1600 sensor, precision voltage measurement
- DC voltage range: 100V, DC current range: +/- 100A, Energy and Battery Capacity Measurement in Watt-hour and Ampere-hour/Coulomb Count
- Measured data can be fed to any micro-controller or Data Acquisition System, Data available on Serial port, Programmable Baud Rate, default is 9600, 16x2 LCD Compatible
- Can be configured as MODBUS RTU slave by connecting it to a TTL to RS485 Converter, programmable Slave ID, default value is 1
- Current Measurement Sensitivity is 22mV/A, Voltage Measurement Sensitivity is 25mV/V
- Diameter 9.0mm conductor through hole
- Over current value can be easily set using potentiometer
- Current Measurement Electrical Isolation 4000V
- Bandwidth > 20kHz, nearly zero magnetic hysteresis
- Push button switch to toggle modes between DC Voltage Current, Watt hour and Ampere hour, over-current value and calibration setting.
- Typical Applications include Test and Measurement Systems, Instrumentation and Control Systems, Motor Control, Power Systems, Solar Systems, Battery Chargers, state of charge estimation, Electric Vehicles, Load Detection, Over-Current Fault Detection, etc.

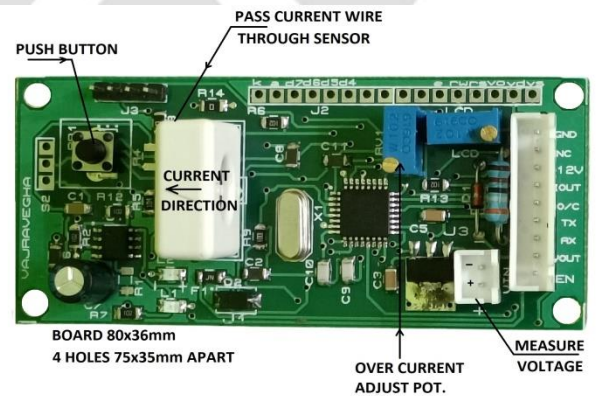

**Description:** VVM302 Voltage Current Sensor Module provides economical and precise voltage and current measurement solution for industrial and commercial applications. It allows system designers to monitor any current path without breaking or changing original system. Current flowing through the 9.0mm sensor slot will generate a magnetic field which is sensed and converted into a proportional voltage. The system uses precision resistors for DC voltage measurement and WCS1600 Hall Effect Sensor for current measurement.



- GND** : Supply Ground
- NC**: Not connected
- +12v** :Power Supply (Auxiliary Supply) 7 to 12 V max
- Iout** : Output Voltage proportional to current, 22mV/A  
Current =  $(I_{out} - 2.5) / 0.022$
- O/C** : Over-Current Detection Digital Output, Low on Over-Current, High otherwise
- Tx** : Serial Data output
- Rx** : Serial Data input
- Vout** : Output Voltage proportional to input voltage, 25mV/V
- EN** : When used as MODBUS slave, connect this pin to DE and RE pins of TTL to RS485 Converter Module

**VIN:** 2 pin connector is for voltage measurement, ensure correct polarity

**Operation:** Connect +12v and GND pins on CONN1. Connect + and – pins of VIN connector to the voltage source to be measured, with correct polarity. Pass the cable (for measuring current) through the on-board white sensor. Current direction is indicated by the arrow on the sensor. Analog Data is available on Vout and Iout, Data is also available on Tx and Rx pins, default Baud Rate is 9600

Format of Serial Data on Tx pin is as shown:

**C99.9D0V99.9D**

where C : Current ,99.9 : Measured Current value

D: D for DC, can be used as delimiter

0 : 0 if No Over-Current Detect, 1 if Over-Current Detect

V : Voltage, 99.9 : Measured Voltage, D : DC

Push button switch allows users to select between following modes available:

<b>Mode 1:</b> DC Voltage and Current	<b>Mode 2:</b> DC Voltage, Current, Wh and Ah
<b>Mode 3:</b> Over-current setting	<b>Mode 4:</b> Zero Current calibration

**Mode 2:** Serial Port outputs V, I, Wh and Ah values as follows:

**C99.9D0V99.9DWh123.4DAh12.3D**

Where C: Current, 99.9 : Measured Current, D: DC (can be used as a delimiter), 0 : 0 if No Over-Current Detect, 1 if Over-Current Detect, V : Voltage, 99.9 : Measured Voltage, Wh: Watt hours, 123.4: Watt hour reading, Ah: Ampere hours, 12.3: Ah reading

To save Wh and Ah values in device memory (to retain values after power off), send character 'S' through the Serial Port and press Enter. To reset Wh and Ah values to 0 in memory, send 'R' through the Serial Port and press Enter. Press push-button switch for one second and release to go from Mode 2 to Mode 3

**Mode 3:** Over Current can be detected by adjusting the preset RV1 for desired value of current. Turn preset clockwise to increase over-current value and anti-clockwise to decrease it. On over current, o/c pin on CONN1 goes low and LED L2 glows. Over-current value is available on Serial Port as "O/C A:25", where 25 is the over-current value.

**Mode 4:** Zero Current Calibration Mode allows the user to reset the current reading to zero when there is no current flowing through the sensor. Calibration may be required if there is error in measured value due to supply voltage variation, temperature variation, etc. To proceed with zero calibration, ensure no current flows through the sensor and long press the push-button in zero current calibration mode till following message is displayed "Done". To maintain accuracy, use a good quality power supply with minimum voltage drift.

**Changing Baud rate:** Default Baud rate is 9600. To change this value, send character 'B' through the Serial Port and press Enter. Following message will be displayed

"Enter Baud Rate 1 to 5; 1-9600; 2-19200; 3-38400; 4-57600; 5-115200"

Type values 1 to 5 as per required Baud rate, and hit Enter key. Restart the system.

The device can be connected to a TTL to USB converter or TTL to RS485 converter, depending on the application.

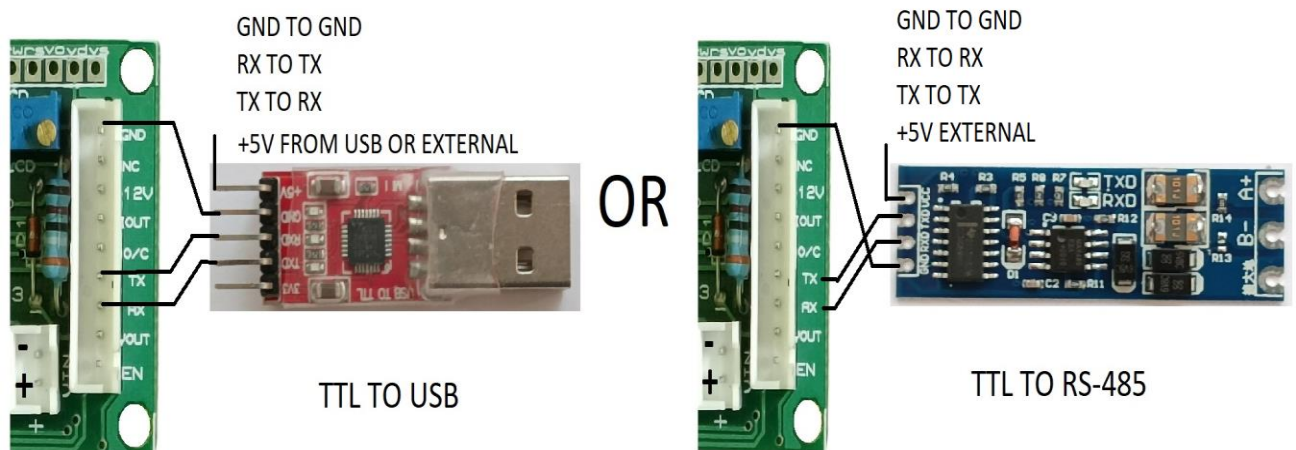

**MODBUS:** The device can be configured as a Modbus slave. Default Slave ID is 1. To change this value, send character 'P' through the Serial Port. Following message will be displayed "**Enter new Slave ID**". Type the new value and press Enter. Restart the system. Only valid slave IDs from 1 to 247 are permitted.

To enter Modbus slave mode, select **Mode 1 or Mode 2**, via push-button switch. Press and hold the push button switch for at-least 10 seconds, and then release the button. Following message will be displayed:  
**SerOn ModOff,Rst** Restart the system. Register format is as follows:

Modbus Register	Value
40001	Voltage (32bit float)
40002	
40003	
40004	Current (32bit float)
40005	
40006	Watt hour (32bit float)
40007	
40008	Ampere hour (32bit float)

In Modbus slave Mode, regular Serial UART communication will not be available, because the data will be communicated via Modbus protocol.

To exit Modbus slave mode, Press and hold the push button switch for atleast 10 seconds in mode1 or 2, and then release the button. Following message will be displayed: **SerOn ModOff,Rst**  
Restart the system. Regular Serial UART Communication will be restored

**NOTE**

- As Hall Effect sensors are used, this system is less accurate for very low current values
- If Serial Port is not in use, connect **Rx** and **NC** pin together, to avoid random display error
- 16x2 LCD can be connected to the 16 pin header on the module if required, LCD contrast can be adjusted by LCD potentiometer

**Calibration Settings**

- I. **Zero Calibration Setting:** This setting is used when the system displays small values of current even when no current is flowing through the sensor. To remove this offset, toggle push-button switch to Mode 4, and '**Set Current to Zero, Long press to Calibrate**' message appears on the Serial Port. Long press push-button till '**Done**' message appears. Restart the system.
- II. **Current and Voltage Calibration Setting (Optional):** To calibrate Current reading, toggle push button to Mode 1 .Press and hold the button for 5 seconds, then release. Current value in Amperes is displayed. Pass current through the sensor (atleast 10A). Adjust RV1 potentiometer till the new reading is equal to the actual current flowing through the sensor. To calibrate, long press the push button till '**Ok**' message appears on the Serial Port; else to skip current calibration, short press the button, to enter voltage calibration. Voltage reading will be displayed. Apply voltage to VIN connector (atleast 10v) and adjust RV1 potentiometer. To calibrate, long press the push button till "**Ok, Rst**" message appears; else to skip calibration, short press the button. Restart the module after calibration.

**Factory Reset:** To restore factory settings, press and hold the push-button switch during power on. '**Factory Reset**' message appears on the Serial Port. Continue to hold the button till Done, Rst message appears. Restart the system. Values will be reset as follows: Baud Rate:9600; Slave ID: 1; Ah and Wh: 0; Calibration state: Original Setting